



FZR 2025-E

Electric Lawnmower

USER'S MANUAL

**Thank you for purchasing this rotary electric lawnmower.
Before you start using it, please, carefully read this user's manual and save it for possible future use.**

TABLE OF CONTENTS

1. GENERAL SAFETY INSTRUCTIONS	4
Important safety information	4
Packaging	4
User's Manual	4
2. SYMBOLS	5
3. DESCRIPTION (FIG. 1).....	6
4. FUNDAMENTALS OF WORK SAFETY.....	7
Other risks	7
Before you start using the lawnmower.....	8
Preparing for operation.....	8
Operation.....	8
Maintenance and storage.....	9
5. ASSEMBLY.....	10
5.1 Installation of the start unit to the top part of the handle.....	10
5.2 Installing the handle	10
5.3 Installing the grass catcher, attaching the wheel cover.....	11
6. OPERATION.....	12
6.1 Setting the mowing height.....	12
6.2 Connecting to the power grid.....	12
6.3 Turning the lawnmower on/off.....	12
6.4 Mowing	13
7. TECHNICAL SPECIFICATIONS.....	14
8. MAINTENANCE.....	15
8.1 Blade replacement.....	15
9. DECLARATION OF CONFORMITY	17
10. DISPOSAL	18

1. GENERAL SAFETY INSTRUCTIONS

IMPORTANT SAFETY NOTICE

- ✿ Carefully unpack the product and take care not to throw away any part of the packaging before you find all the parts of the product.
- ✿ Store the product in a dry place out of reach of children.
- ✿ Read all warnings and instructions. Not following warnings or instructions may lead to injury by electrical shock, a fire and/or serious injuries.

PACKAGING

The product is packed in a package that prevents damage during transport. This package is a resource and so can be handed over for recycling.

INSTRUCTIONS FOR USE

Before you start working with the machine, read the following safety and usage instructions. Acquaint yourself with the operating elements and the correct use of the machine. Keep the user's manual in a safe place where it can be easily retrieved for future use. Save the original packaging, including the internal packing material, warranty card and proof of purchase receipt at least for the duration of the warranty. If you need to ship this machine, pack it in the original cardboard box to ensure maximum protection during shipping or transport (e.g. when moving or when sending it for repair to a service centre).

-  **Note:** If you hand over the power tool to somebody else, do so together with this user's manual. Following the instructions in the included user's manual is a prerequisite for the proper use of the machine. The user's manual also contains operating, maintenance and repair instructions.

The manufacturer takes no responsibility for accidents or damages resulting from not following the instructions in this manual.

2. SYMBOLS



Read the manual with the instructions before using this machine.



Bystanders must be at a sufficient distance.



Be careful of the sharp blade edges. The blades continue to rotate even after the motor is turned off. Before carrying out maintenance or if the power cord is damaged, disconnect the power plug from the mains.



Keep the flexible power cord at a sufficient distance from the blade.



The blades will continue rotating even after the machine is turned off. Before touching any of the machine's components, wait until they come to a complete stop.



Do not mow grass in the rain and do not leave the lawnmower uncovered when it is raining.



Use hearing protection.

Use eye protection.

Use breathing organ protection.



Always disconnect the power cord before working on the mowing deck

3. DESCRIPTION (FIG. 1)

1. Top Handle
2. Start unit
3. Start button
4. Start lever
5. Nut with quick coupler
6. Bottom part part of the handle
7. Safety grass catcher cover
8. Transport handle
9. Lawnmower chassis
10. Wheels
11. Grass catcher
12. Full grass catcher indicator

Fig. 1

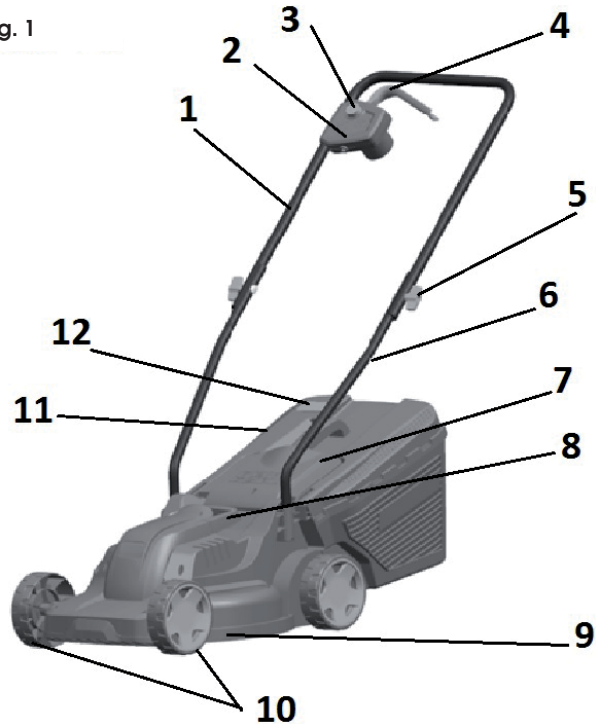

4. FUNDAMENTALS OF WORK SAFETY

- ✿ Never use the machine if the power cord is damaged or visibly worn out.
- ✿ In the event that you connect the lawnmower using a damaged power cord to a power source and then touch the place that is uninsulated before the lawnmower is disconnected from the power source, you subject yourself to a risk of injury by electrical shock.
- ✿ Likewise, never touch the blades until the machine is disconnected from the power source and until the blades come to a complete stop.
- ✿ Make sure that the extension cord never comes into contact with the blades. The blades could damage the insulation on the power cord and this would create a risk of injury by electrical shock when a certain part of the body and the exposed wire touch while it is under live current.
- ✿ Disconnect the machine from the voltage source (i.e. pull the plug on the power cord out of the mains power socket):
 - If you need to leave the machine without supervision
 - If you are planning to carry out troubleshooting
 - Prior to every inspection, every cleaning or repairs
 - If you impact a foreign object when working with it
 - If the machine vibrates excessively.
- ✿ Carefully study the fundamentals of work safety with the machine and the user's manual.
- ✿ Recommendation: Connect the machine only to such a power source that is equipped with a residual current device (RCD) with a maximum leakage current of 30mA.
- ✿ If the power cord is damaged, it must be replaced by the manufacturer or by a customer service centre.
- ✿ This machine must not be operated by persons with limited physical, sensory or mental abilities (including children). Furthermore, it must not be used by inexperienced persons whose technical knowledge for the operation of this machine is insufficient. These persons may operate the machine under the supervision of a competent person or after being duly instructed about the fundamentals of work safety.
- ✿ If children are moving around in the vicinity of the machine, it is necessary to watch that they do not play with the machine.
- ✿ A tingling sensation in one's hands or their numbness are indications of excessive vibrations. If this happens, shorten the work cycle, take sufficiently long breaks, share the work among several people or in the event of long term use of the lawnmower, use special anti-vibration gloves when working.
- ✿ An unavoidable associated consequence of using the lawnmower is that it emits noise when it is running. Therefore, perform noisy work only during dedicated hours, respectively at a time when this type of activity is normal. Respect quiet times and try to limit the work to the shortest possible duration. Likewise, we recommend that you and persons in the near vicinity of the lawnmower wear hearing protection.

OTHER RISKS

- ✿ Despite the fact that our products are designed to meet the valid technical norms and safety directives in force, there still remain certain risks to the user associated with the operation of the machine:
 - Stones and other fragments may fly out of the area of the mowing deck.
 - If the operator of the machine fails to use hearing protection, then they risk subsequent deafness.
 - Finger injury during blade maintenance
 - Inhalation of grass clipping particles
 - Electrical shock when uninsulated parts are touched.

- ✿ This machine must not be operated by persons with limited physical, sensory or mental abilities (including children) or inexperienced persons or persons whose technical knowledge is evidently insufficient for the given task; and such people should only operate the device under the supervision of a person that is competent for this task or in the case where such a person is thoroughly instructed about work safety with the machine.
- ✿ If children are moving around in the vicinity of the machine, it is necessary to watch that they do not play with the machine.

⚠ ATTENTION! Carefully read the user's manual before using this lawnmower. Make sure that you have thoroughly acquainted yourself with all the control elements. Following the work safety rules for the machine minimises the risk of a fire, injury by electrical shock or mechanical injuries.

- ✿ Carefully store the user's manual in case it is needed.
- ✿ Incorrect operation of the machine creates a risk of injury. The lawnmower may cause serious injury to the user and persons located nearby and therefore these work safety rules should be always be followed to eliminate this risk if possible.
In this sense the user is responsible for safety when working with the machine. Likewise, never use the machine in the event that any of its safety elements are missing or not in full working order.

BEFORE YOU START USING THE LAWNMOWER

- ✿ Carefully read all the instructions provided in this user's manual. Thoroughly acquaint yourself with the machine's control elements and the fundamentals for correct use.
- ✿ Never permit children or persons of whom you are not certain that they are acquainted with the control elements and the work safety rules for this machine to work with the machine on their own. National legislation may, likewise, stipulate a minimum age limit from which it is permitted to operate this type of machine independently. Please acquaint yourself with the relevant laws governing this area in your country.
- ✿ Never use the lawnmower in the event that persons, particularly children or household pets, will be freely moving in its vicinity.
- ✿ Always keep in mind that potential injuries or damages to property caused by the operation of this machine are the full responsibility of its user.

PREPARING FOR OPERATION

- ✿ When working with the machine it is necessary to wear suitable footwear and long pants. Never work with the lawnmower if you are barefoot or if you are wearing only sandals.
- ✿ Before starting work, inspect the terrain and remove any objects that could be deflected by the machine.

⚠ ATTENTION! Before every use of the machine, make sure that the blade, its mounting pin and the lawnmower body in general is not damaged or excessively worn out. If you wish to replace a damaged or worn out part, of which there are sets on the machine, always replace the entire set so that your action does not cause imbalance.

OPERATION

- ✿ Only operate the machine during daylight hours or under sufficient artificial lighting.
- ✿ If possible, do not mow wet grass.
- ✿ Make sure that during work you always have firm support and a secure stance.

- ✿ Do not run when pushing the mower but rather walk at a normal pace.
- ✿ The following general rules apply for work with the lawnmower: When mowing vegetation on a slope, one does not move up and down but always along the contours, i.e. horizontally perpendicular to the incline of the slope.
- ✿ Be very careful whenever you change direction on a slope.
- ✿ Never use the lawnmower on extremely steep slopes.
- ✿ In the event that you need to pull the lawnmower towards yourself while it is running or if you need to travel backwards with the lawnmower, pay increased attention when doing this.
- ✿ Always stop the blades from running in the event that the machine is being transported anywhere or if you are travelling over an area not covered by grass.
- ✿ Never use the machine if you find that any covers on it are damaged or if any of its safety elements are missing such as deflectors or grass catchers.
- ✿ Always start the motor as is described in the user's manual, while ensuring to keep your feet away from the blades when performing this task.
- ✿ Never fill the machine when starting the motor unless it is really essential in order to start it. In such a case, turn the side of the lawnmower upwards that is farther away from you.
- ✿ Never insert your hands or feet under the lawnmower, in particular near to moving parts. Never cover the grass ejection chute.
- ✿ Never transport the machine if the motor is still running.
- ✿ Always first stop the motor and pull the plug of the power cord out of the socket; only then is it possible to start troubleshooting or to empty the grass catcher.
 - Proceed in the same way before any inspection, every cleaning or every repair of the machine.
 - In the event that you impact a foreign object, check that the lawnmower has not been damaged, and if so, it is necessary to repair this damage before starting the motor again.
 - Or if the machine starts to vibrate with unusual intensity (immediately check the machine!)
- ✿ Stop the motor whenever you move away from the machine.

MAINTENANCE AND STORAGE

- ✿ Make sure that all nuts, pins and bolts are always securely tightened so as to ensure the safe operation of the machine.
- ✿ Regularly check the grass catcher for damage or excessive wear and tear.
- ✿ Immediately replace worn out or damaged parts for new ones. This will contribute to the safe operation of your lawnmower.
- ✿ When setting adjustable elements, take care not to clamp your fingers between the moving blades and the fixed part of the machine. If you wish to store the lawnmower in an enclosed area, first allow its motor to cool down.

5. ASSEMBLY

For the purpose of transportation, the lawnmower is supplied disassembled. Before use, it must be assembled according to the following steps:

5.1 INSTALLATION OF THE START UNIT TO THE TOP PART OF THE HANDLE

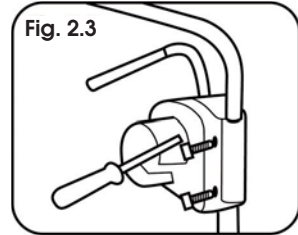
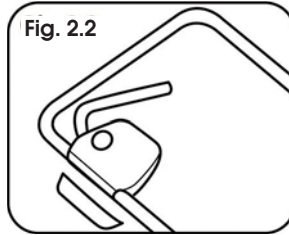
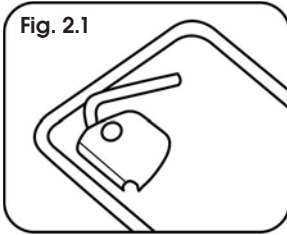

- ✿ Place the start unit against the handle, see figure 2.1
- ✿ Put on the bottom fastening part, see figure 2.2
- ✿ Join both parts together using the included screws and tighten appropriately. Figure 2.3

5.2 INSTALLING THE HANDLE

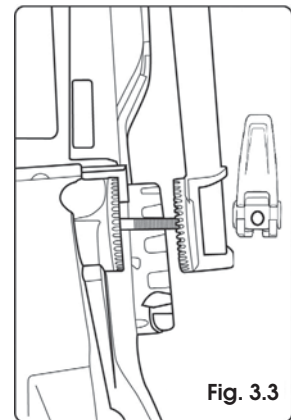
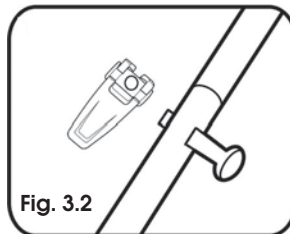
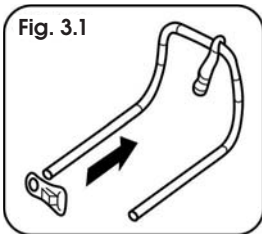

- ✿ Prior to installing the handle, slide the power cord holding hook on to the top part. Figure 3.1
- ✿ Connect the top and bottom part of the handle using the included screws and nuts with quick coupler levers. Figure 3.2
- ✿ Connect the bottom part of the handle to the lawnmower. Figure 3.3
- ✿ Attach the power cord to the handle using the plastic clips.

 **Note:** The handle is height-adjustable and can be folded down for storage.

5.3 INSTALLING THE GRASS CATCHER, ATTACHING THE WHEEL COVER

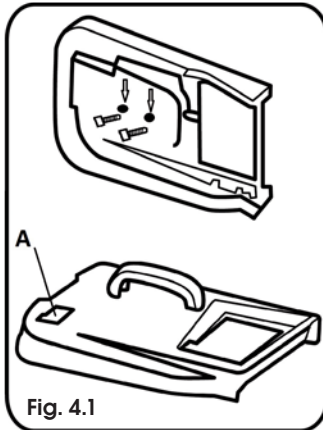

Fig. 4.1

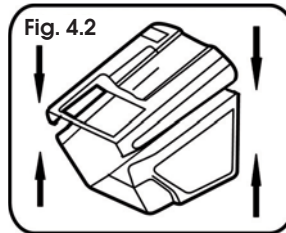

Fig. 4.2

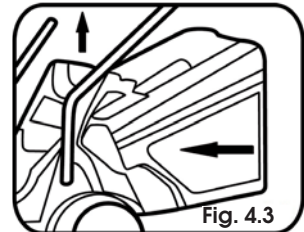

Fig. 4.3

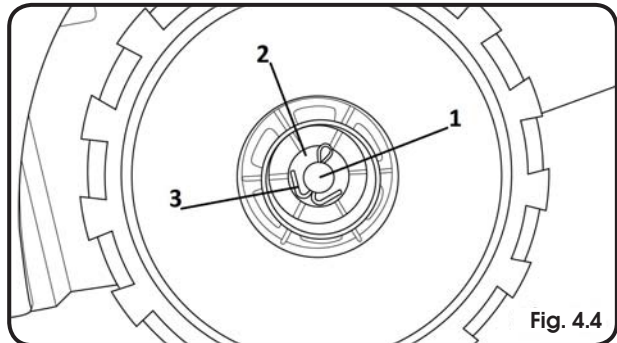

Fig. 4.4

- ✿ Attach the handle to the top part of the grass catcher using the included screws. Figure 4.1
- ✿ Connect the top and bottom part of the grass catcher. Figure 4.2
- ✿ To seat the grass catcher on to the lawnmower, it is first necessary to lift the rear safety grass catcher cover. Figure 4.3
- ✿ Put the lawnmower wheel on to the axle. Figure 4.4, point 1. Put on the washer and secure in place using the cotter pin. Figure 4.4, point 2 and 3.
Finally put on the wheel cover. Repeat this procedure for all 4 wheels.

⚠ ATTENTION: The grass catcher is equipped with a full indicator. Figure 4.1, point A. If the flap is lifted, the grass catcher is not full. Otherwise, it is necessary to tip out the grass catcher.

6. OPERATION

6.1 SETTING THE MOWING HEIGHT

- ⚠ **ATTENTION:** Before setting the mowing height, always make sure that the lawnmower is turned off and the blade is not moving.
- ⚠ **ATTENTION:** The blade will rotate several seconds after the lawnmower is turned off. A rotating blade may cause injuries.

The mowing height is set in 3 positions independently on the front and rear wheel axle.

1. position 20 mm
2. position 38 mm
3. position 56 mm

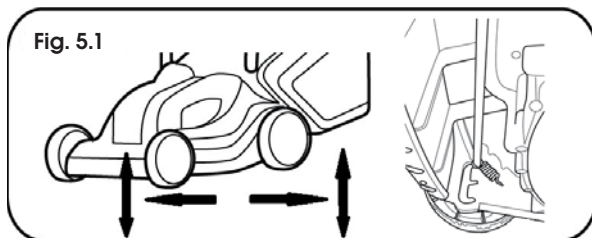

- ✿ Setting the height of the front wheels - pull the wheel away from the grass catcher and select the desired height. Follow this procedure for both front wheels. Figure 5.1
- ✿ Setting the height of the rear wheels - pull the wheel towards the grass catcher and select the desired height. The height should be the same as on the front wheels. Follow this procedure for both rear wheels. Figure 5.1

⚠ **ATTENTION:** Make sure that the height of all 4 wheels is set the same

📖 **Note:** Lawns made up of standard grass blends should not be mowed to a height lower than 4 cm. Lawn should not be shortened by more than 1/3 of its height.

6.2 CONNECTING TO THE POWER GRID

Insert the plug on the power cord into the power grid (230-240 V, 50 Hz).

Check that there is a sufficient length of power cord available.

The length of the power cord should not exceed 30 m. The lawnmower may lose power when a longer power cord is used.

6.3 TURNING THE LAWNMOWER ON/OFF

⚠ **ATTENTION:** Do not start the lawnmower when it is standing in a place with tall grass.

Turning on:

Press and hold the safety button. Figure 6, point A. Then pull the starting lever to the handle. Figure 6, point B. Release the safety button.

Turning off:

Release the starting lever (Figure 6, point B)

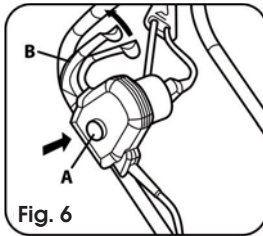

⚠ ATTENTION: The blade will rotate several seconds after the lawnmower is turned off.

⚠ ATTENTION: Do not turn the lawnmower off and on in quick succession.

6.4 MOWING

⚠ ATTENTION: Mow the lawn only when it is dry. Mowing wet grass causes undesirable clogging of the lawnmower and subsequent loss in power and reduced grass collection performance.

⚠ ATTENTION: Always mow in the direction away from the power cord. In this way, you will prevent accidentally severing the power cord. Figure 7.

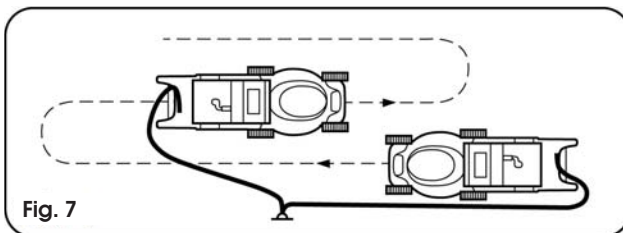

7. TECHNICAL SPECIFICATIONS

Model	FZR 2025 E
Power supply	230-240 V, 50 Hz
Power input	1300 W
Idling speed	3,400 min ⁻¹
Coverage width (blade length):	320 mm
Mowing heights	20/38/56 mm - 3 positions
Grass catcher volume	30 l
Weight when empty:	7.25 Kg
Noise level	according to norm EN ISO 3744
Guaranteed emission level of acoustic power (LWA max) in accordance with the Noise Level Directive 2000/14:	
LwA MAX	96 dB (A)
Vibrations:	< 30 m/s ²

8. MAINTENANCE

⚠ ATTENTION! Before proceeding to remove the grass catcher, always turn off the lawnmower and pull the plug on the extension cord out of the power socket.

📖 Note: We recommend that you regularly perform the maintenance described below, this will increase the lifetime of the machine and increase its reliability.

- ✿ Regularly visually inspect the machine for the timely identification of defects such as a loose blade, blade installed upside down, blade damage or damaged or excessively worn out parts.
- ✿ Likewise, regularly check that the protective covers or protective elements are not damaged and that they are in their place.
- ✿ Before every use of the machine, perform all necessary repairs and maintenance.
- ✿ In the event that despite regular maintenance, the machine does not work, please contact our customer service, the potential repair should be carried out by our contractual partner in one of the specialised workshops of the Fieldmann brand.

8.1 BLADE REPLACEMENT

For this task, we recommend that you contact an authorised service centre.
Always use original spare parts.

Before inspecting the blade, always disconnect the lawnmower from the electricity grid and check that the motor is turned off.

⚠ ATTENTION: Remember that the blade still rotates several seconds after the motor is turned off. Never attempt to stop the blade. In regular intervals, check that the blade is securely fastened, in good condition and sharp. If necessary, sharpen or replace it.

In the event that the blade hits an object while mowing, turn the lawnmower off and wait until the blade comes to a stop. Then check the condition of the blade and its fastening bolts.

If these are damaged or if they have been lost then they must be replaced without delay.

Important: While working use protective gloves.

Loosen the two bolts that hold the blade (6 mm Allen key) by turning anticlockwise, remove the blade and replace it with a new one. Check that the new blade is installed in the correct direction. Tighten the plastic nut of the fastening bolt turning clockwise.

- ✿ Turn the lawnmower upside down
- ✿ Secure the blade against movement using a screwdriver. Figure 8.1
- ✿ Loosen the blade bolt and remove the blade. Then retighten firmly. Figure 8.2

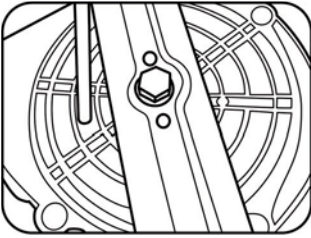

Fig. 8.1

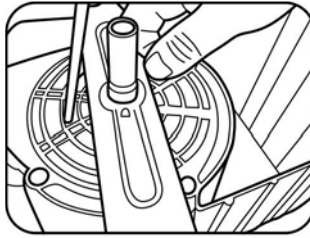

Fig. 8.2

9. DECLARATION OF CONFORMITY

DECLARATION OF CONFORMITY

Manufacturer:

FAST ČR, a. s.

Černokostelecká 2111, 100 00 Prague 10, Czech Republic

Tax ID number: CZ26726548

Product/brand: ELECTRIC LAWNMOWER / FIELDMANN**Type/model:** FZR 2025 E as factory model EAL-21008-5

220–230 V~, 50 Hz, 1300 W

This product meets the requirement of the directives and regulations below:

ES Council Directive No. 2006/42/ES for machinery

ES Directive No. 2014/30/EU for electromagnetic compatibility (EMC)

ES Directive No. 2011/65/EU on the reduction of hazardous substances in electrical and electronic equipment

and norms:

EN 60335-1:2012+A11

EN 60335-2-77:2010

EN 62233:2008

EN 55014-1:2006+A1:2009+A2:2011

EN 55014-2:2015

EN 61000-3-2:2014

EN 61000-3-3:2013

CE mark: 16**Place of issue:** Prague**Date of issue:** 1. 8. 2016**Name:** Ing. Zdeněk Pech

Board Chairman

Signature:

FAST FAST ČR, a. s. ©
Černokostelecká 1621, 251 01 říčany
IČO: 26726548 tel.: +420/ 323 204 111
DIČ: CZ26726548 fax: +420/ 323 204 110



10. DISPOSAL

INSTRUCTIONS AND INFORMATION REGARDING THE DISPOSAL OF USED PACKAGING MATERIALS

Dispose of used packaging material at a site designated for waste in your municipality.

DISPOSAL OF USED ELECTRICAL AND ELECTRONIC EQUIPMENT



This symbol on products or original documents means that used electric or electronic products must not be added to ordinary municipal waste. For proper disposal, renewal and recycling hand over these products to determined collection points. Or as an alternative in some European Union states or other European countries you may return your products to the local retailer when buying an equivalent new product. Correct disposal of this product helps save valuable natural resources and prevents damage to the environment caused by improper waste disposal. Ask your local authorities or collection facility for more details. In accordance with national regulations penalties may be imposed for the incorrect disposal of this type of waste.

For business entities in European Union states

If you want to dispose of electric or electronic appliances, ask your retailer or supplier for the necessary information. Disposal in other countries outside the European Union. This symbol is valid in the European Union. If you wish to dispose of this product, request the necessary information about the correct disposal method from the local council or from your retailer.



This product meets all the basic requirements of EU directives related to it.

Changes in the text, design and technical specifications may be made without prior notice and we reserve the right to make such changes.

User s manual in the original language.