

SENCOR®

Let's live!

**DIGITAL AUDIO SYSTEM
WITH BLUETOOTH
SSS 3800**

**USER'S MANUAL
EN**



Table of Contents

Safety Instructions.....	2
Guide to the Appliance.....	4
Getting Started.....	5
Operation instruction.....	6
Technical Specifications.....	10

Safety Instructions

This product has been designed with the utmost safety in mind.

However, incorrect use may lead to electric shock or fire. This is why users should observe the following instructions when using this device.

This device uses a semiconductor unit and contains no user serviceable parts. Do not disassemble this device, otherwise you are exposed to the risk of electric shock. If any damage to this product occurs, please have this product repaired by a qualified service technician.

Power source

Power supply of this unit must be match the serial plate data.

Heat source

Keep this unit out of heat sources like stove or direct sunlight.

Cleaning

Prior to cleaning, please disconnect power first. For cleaning, don't use liquid detergents or caustic liquids - just clean the unit with a soft cloth.

Heavy objects

Do not place heavy objects on the unit, otherwise damage might occur.

Connecting other devices

Before connecting other devices to this unit, please make sure to disconnect power. Otherwise damage to the unit or personal injury might occur.

Faults to be repaired

If any of the following problems occurs, please disconnect power to the unit and contact a qualified service technician.

- A. Power cord or plug is damaged.
- B. Liquids or other foreign objects have penetrated inside the product.
- C. If the unit does not work even if it's being operated according to the instructions, don't press any buttons other than those described in these instructions. Otherwise, damage to this unit may occur along with a more demanding repair.
- D. This unit has fallen on the ground from a big height.
- E. Burns can be smelled from the product inside.

Maintenance

If you don't have enough technical knowledge necessary to maintain this unit, don't attempt to repair it by yourself. By removing cover, you are exposed to a risk of electric shock. If needed, please contact a qualified service technician.

Replacement of parts

If you need to replace any part of this unit, ask your service technician to make a replacement for equal spare part models. If other spare part models are used for replacement, serious damage, electric shock or shortening the unit's lifetime may occur.

Safety check

When done with the maintenance, ask your service technician to perform an on-site safety check to make sure that the unit's operation is safe.

Note:

Before using this product, read these instructions carefully and keep it well for future use.

Guide to the Appliance

Top View

1. 3.5mm AUX IN JACK
2. 6.3mm MIC JACK 1
3. 6.3mm MIC JACK 2
4. USB PORT 1
5. USB PORT 2
6. 10/M./FOLD.+ BUTTON
7. LIGHT BUTTON
8. 10/M./FOLD.- BUTTON
9. ECHO BUTTON
10. EQ BUTTON
11. FUNCTION/STANDBY BUTTON
12. ◀◀/TUN.- BUTTON
13. ▶▶/TUN.+ BUTTON
14. P-MODE/M. BUTTON
15. ▶▶/PAIR/SCAN BUTTON
16. LCD DISPLAY
17. PAIR INDICATOR
18. SUPER BASS BUTTON
19. POWER ON/OFF BUTTON
20. CHARGE INDICATOR
21. MIC VOL. CONTROL
22. VOLUME CONTROL

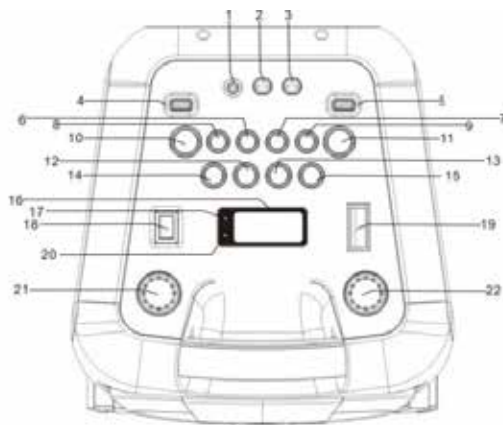

Front and Back view

23. HANDLE
24. SPEAKERS
25. DECORATIVE CIRCLE
26. TWEETERS
27. FM ANTENNA
28. VENTILATION HOLES
29. AC SOCKET
30. DECORATION LEDS

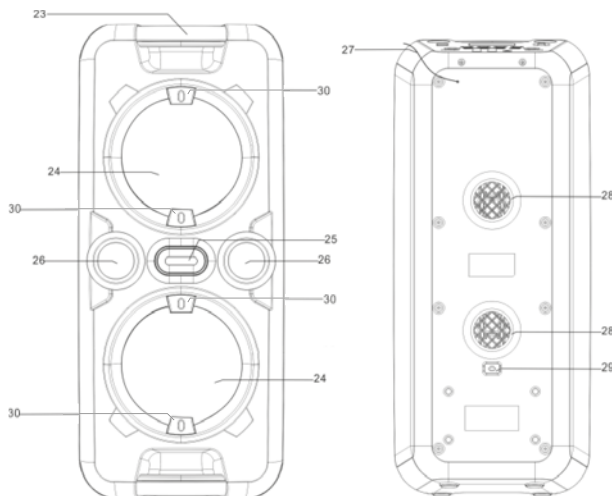

Getting Started

POWER SOURCE

This unit works with rechargeable lead-acid battery (the battery capacity 4000mAh). Fully charge the unit (around 7 hours) before using the product for the first time. The playback time has about 2hours after full charging. Unplug the AC Power cord from the AC socket to work on the battery pack after fully charged. Plugging the AC Power cord while the battery pack is attached initiates the charging of this battery, the charge LED indicator lights red during charging, when the battery is fully charged the indicator will turn to green. When the unit is with low battery, the LED indicator will flash in red.

Warning:

Do not change the battery, only high-qualified personnel can perform this operation.

**Attention:**

Before turning it on, make sure that the voltage in your power grid corresponds to the voltage indicated on the rating label. In the interest of your own safety, carefully read the following instructions before first connection of this device to the power grid. If you wish to operate this device, insert the power cord into a power socket with a voltage of 230 V 50 Hz and turn it on by the POWER ON/OFF BUTTON on the top panel.

Operation instruction

BASIC FUNCTION

TURNING THE UNIT ON/OFF

Press the power ON/OFF button to switch the unit on/off.

SETTING THE FUNCTION MODE

To change the function modes, press the **FUNCTION/STANDBY** button repeatedly to choose USB1/USB2/BLUETOOTH/AUX/RADIO function.

ADJUSTING THE VOLUME

1. Rotate the **VOLUME** knob on the unit to increase or decrease the music volume.
2. Rotate the **MIC VOL.** knob on the unit to increase or decrease the microphone volume.

BASS ADJUSTMENT

Press the **SUPER BASS** button on unit to increase the bass effect.

EQUALIZER (EQ) FUNCTION

This unit has a built-in equalizer system, Press the **EQ** button on unit to select a setting that best matches the music style: FLAT, CLASSIC, ROCK, POP and JAZZ.

MICROPHONE ECHO ADJUSTMENT

Press the **ECHO** button on unit turn on or off the microphone echo effect.

FLASHING LIGHT

There are 5 modes for the DISCO LED lighting. Press the **LIGHT** button to choose the light modes. To inactivate the light, press the **LIGHT** button until "OFF" showed on the display.

L-1: By default mode, blue LED will be on constantly when it is selected.

L-2: Blue LED will be on flashing mode.

L-3: Red LED will be on constantly.

L-4: Red LED will be on flashing mode.

L-5: 7 colors LED will be on flashing mode.

RADIO OPERATION

Listen to FM radio broadcasts. Press the **FUNCTION/STANDBY** button on the unit, the display reads FM and the radio frequency.

Note: in order to get the best reception, extend the FM ANT. on the rear of the unit before use to its full length.

TUNING TO A RADIO STATION

If you know the station frequency that you want to tune to directly:

- Tune to a station by press the **▶▶I/TUN.+** or **I◀◀/TUN.-** button repeatedly. Hold them to search upward or downward. The station frequency is shown on the display.
To tune to a preset station:
- To tune to the next preset station, press the **10/M./FOLD.+** button.
- To tune to the previous preset, press the **10/M./FOLD.-** button.

AUTO PRESET MEMORY / SCAN

To scan for stations within reception range and save them to preset memory automatically, press and hold the **PLAY/PAUSE/PAIR/SCAN** button. After the unit is finished scanning, the unit will automatically tune to preset number 1 (P01).

MANUAL PRESET MEMORY OPERATION

Choose which stations to save in preset memory instead of scanning automatically.

1. Use the **▶▶I/TUN.+** or **I◀◀/TUN.-** button to tune to the station that you want to save as a preset (e.g., 93.1).
2. Press the **P-MODE/M.** button. "P01" will flash on the display to indicate that you are saving the station as Preset Memory 01. (To change the preset memory number, press the **10/M./FOLD.+** or **10/M./FOLD.-** buttons.)
3. Press the **P-MODE/M.** button to finish saving the station (e.g., P01 is now set to 93.1).
4. To save another station, repeat steps 1 to 3. You may save up to 30 FM stations.

USB OPERATION

This unit provides two USB ports for music playback.

1. Press the **FUNCTION/STANDBY** button on unit to select "USB1" or "USB2" mode.
2. Plug the USB memory stick to the USB port on top of the unit. Playback will start automatically from Track 1.
3. To pause playback, press the **PLAY/PAUSE/PAIR/SCAN** button on unit. The playing time will flash on the display.
4. To resume playback, press the **PLAY/PAUSE/PAIR/SCAN** button again.
5. To select a desired track, press the **▶▶I/TUN.+** or **I◀◀/TUN.-** button respectively during playing until the desired track appears on the display. The unit will start play automatically.
6. To search for a particular passage during playback, press and hold the **▶▶I/TUN.+** or **I◀◀/TUN.-** button to scan the current playing track at high speed until desired point (passage) appears, then release the button for normal playback mode.
7. To select a song which track number exceeds 10, press the **10/M./FOLD.+** or **10/M./FOLD.-** button each time to skip forward/backward 10 tracks, then press the **▶▶I/TUN.+** or **I◀◀/TUN.-** button to select desired track.
8. To select a desired folder (if the USB contains more than one folder), press and hold the **10/M./FOLD.+** or **10/M./FOLD.-** button each time to skip forward/backward a folder, then press the **▶▶I/TUN.+** or **I◀◀/TUN.-** button to select desired track.

Important:

The USB port is intended for data transfer only, other devices cannot be used with this USB connection. The use of USB extension cords is not recommended. Don't unplug the USB from the unit when playing or reading the USB device.

**Attention:**

With respect to the variety of devices on the market, the compatibility and playability of all media is not guaranteed. Memory devices that you wish to connect should be tested in advance or formatted to the FAT32 file format. It may not be possible to playback protected media, files or content contained on them. Playback tested and unprotected media and content.

Note:

Media with a power consumption greater than flash memory should only be connected if it has its own power source.

REPEAT PLAY

You can play one track or all tracks on the USB repeatedly.

To Repeat a Single Track

1. Press **P-MODE/M.** button on unit during play, the display will show "↶" and the current track will be played over and over again.
2. To cancel repeat play, press **P-MODE/M.** button on unit until "↶" disappears from the display.

To repeat all the Tracks

1. Press **P-MODE/M.** button on unit until the "↷" shows steadily on the display, all tracks on the USB will be played over and over again.
2. To cancel repeat play, press the **P-MODE/M.** button on unit until "↷" disappears from the display.

To repeat the folder (only for USB which contains more than one folder)

1. Press the **P-MODE/M.** button on unit until "↷ FOLDER" shows steadily on the display, the current folder will be repeated over and over again.
2. To cancel repeat play, press the **P-MODE/M.** button on unit until "↷ FOLDER" disappears from the display.

RANDOM PLAY

Press the **P-MODE/M.** button on unit in play mode till the "**RAND**" shows steadily on the display, the random play will start from next track automatically. Press the **P-MODE/M.** button on unit again until the "**RAND**" disappears from the display to cancel.

BLUETOOTH OPERATION

1. Press the **FUNCTION/STANDBY** button on unit to switch to BLUETOOTH function, the LCD will display "**bt**" and the pair indicator will flash at high speed.
2. Turn on the Bluetooth function on the device, scan the unit "**SSS3800**" and connect, then input the password 0000 if required, the pair indicator keep light up to indicate connection done, and the display will show "**bt**". Press Play to start playback.
3. Rotate the **VOLUME** knob on the unit or adjust the volume on the external device to increase or decrease the music volume to your desired level.
4. Press and hold the **PLAY/PAUSE/PAIR/SCAN** button to disconnect Bluetooth.

Note:

The Bluetooth works best within 10 meters in open air.



Attention:

Some connected devices can support an undivided volume settings. If one of the connected devices do not support this function then the volume adjustment will work on both devices separately.

AUX-IN OPERATION

1. Press the **FUNCTION/STANDBY** button on unit to select the "AUX" mode.
2. Connect your audio device to the AUX IN jack on the top panel of the unit with an AUX IN cable.
3. Rotate the **VOLUME** knob on the unit or adjust the volume on the external device to increase or decrease the music volume to your desired level.
4. Control the playback with your audio device.

MIC JACK OPERATION

Microphone input is available in all modes.

1. Connect your microphone to the 6.3mm **MIC JACK** found on the top panel of the unit.
2. Rotate the **MIC VOL.** knob on the unit to increase or decrease the microphone volume.
3. Press the **ECHO** Button to turn on or off the echo effect of the microphone.

Technical Specifications

SSS 3800

Power Sound System

Power: 60W

LCD Display

Flashing LED Backlight

Sound:

Power Output: 60W (Impedance: 3 Ω for Mid-Range Speakers)

4 Speakers (2 Mid-Range + 2 Treble)

Frequency Response: 40Hz-15KHz

Total Harmonic Distortion: $\leq 10\%$ (1KHz)

Equalizer Modes (FLAT, CLASSIC, ROCK, POP, JAZZ)

SUPER BASS Button

Light:

7 Colors Light Show

5 Flashing Modes

Reception:

FM PLL Radio

Station Presets: 30 FM

Inputs:

Bluetooth Audio 2.1

Audio Aux (3.5mm Stereo Jack)

2x USB (Playback)

2x Microphone Port (Jack 6.3mm)

Others:

In-built Rechargeable Battery 4000mAh

Karaoke (Echo, Volume)

Power Supply: AC 100-240V - 60/50 Hz

Energy Efficiency: $< 0.5W$

Dimension: 259 x 272 x 595mm

Weight: 7.16kg

Note:

Specifications are subject to change for continuous improvement without prior notice.

INSTRUCTIONS AND INFORMATION REGARDING THE DISPOSAL OF USED PACKAGING MATERIALS

Dispose of packaging material at a public waste disposal site.

DISPOSAL OF USED ELECTRICAL AND ELECTRONIC APPLIANCES



The meaning of the symbol on the product, its accessory or packaging indicates that this product shall not be treated as household waste. Please, dispose of this product at your applicable collection point for the recycling of electrical & electronic equipment waste. Alternatively in some states of the European Union or other European states you may return your products to your local retailer when buying an equivalent new product. The correct disposal of this product will help save valuable natural resources and help in preventing the potential negative impact on the environment and human health, which could be caused as a result of improper liquidation of waste. Please ask your local authorities or the nearest waste collection centre for further details. The improper disposal of this type of waste may fall subject to national regulations for fines.

For business entities in the European Union

If you wish to dispose of an electrical or electronic device, request the necessary information from your seller or supplier.

Disposal in other countries outside the European Union

If you wish to dispose of this product, request the necessary information about the correct disposal method from local government departments or from your seller.



The product meets EU requirements.

Hereby, FAST ČR, a.s. declares that the radio equipment type SSS 3800 is in compliance with Directive 2014/53/EU.

The full text of the EU declaration of conformity is available at the following internet address: www.sencor.eu

Changes in the text, design and technical specifications may be made without prior notice and we reserve the right to make such changes.

The original version is in the Czech language.

Address of the manufacturer: FAST ČR, a.s., Černokostelecká 1621, Řiřany CZ-251 01

SENCOR®

EN Warranty conditions

Warranty card is not a part of the device packaging.

This product is warranted for the period of 24 months from the date of purchase to the end-user. Warranty is limited to the following conditions. Warranty is referred only to the customer goods using for common domestic use. The claim for service can be applied either at dealer's shop where the product was bought, or at below mentioned authorized service shops. The end-user is obligated to set up a claim immediately when the defects appeared but only till the end of warranty period. The end user is obligated to cooperate to certify the claiming defects. Only completed and clean (according to hygienic standards) product will be accepted. In case of eligible warranty claim the warranty period will be prolonged by the period from the date of claim application till the date of taking over the product by end-user, or the date the end-user is obligated to take it over. To obtain the service under this warranty, end-user is obligated to certify his claim with duly completed following documents: receipt, certificate of warranty, certificate of installation.

This warranty is void especially if apply as follows:

- Defects which were put on sale.
- Wear-out or damage caused by common use.
- The product was damaged by unprofessional or wrong installation, used in contrary to the applicable instruction manual, used in contrary to legal enactment and common process of use or used for another purpose which has been designed for.
- The product was damaged by uncared-for or insufficient maintenance.
- The product was damaged by dirt, accident of force majeure (natural disaster, fire, and flood).
- Defects on functionality caused by low duality of signal, electromagnetic field interference etc.
- The product was mechanically damaged (e.g. broken button, fall).
- Damage caused by use of unsuitable media, fillings, expendable supplies (batteries) or by unsuitable working conditions (e.g. high temperatures, high humidity, quakes).
- Repair, modification or other failure action to the product by unauthorized person.
- End-user did not prove enough his right to claim (time and place of purchase).
- Data on presented documents differs from data on products.
- Cases when the claiming product cannot be indentified according to the presented documents (e.g. the serial number or the warranty seal has been damaged).

Authorized service centers

Visit www.sencor.eu for detailed information about authorized service centers.